

FRENIC  
**MEGA**

# REFLEX

## VARIABLE SPEED DRIVE UNIT FOR **MEGA** DRIVES

*Instruction Manual*



### Contents

- Installation
- Set Up & Operation
- Troubleshooting
- Quoting Guide
- Comprehensive Parts Listing

**STOP  
READ FIRST**

BEFORE installing Drive or calling Customer Service for assistance, please read this Manual in full. We have very few questions, problems or complaints when Manual is read and followed.  
Thank you.

## **REFLEX**

### **TABLE OF CONTENTS**

IMPORTANT NOTICE .....	3
Before You Begin .....	4
Introduction .....	5
Electrical Specifications .....	7-8
Fuji Frenic Inverter Ratings .....	9-10
Stand-Alone Inverter .....	11-14
Deluxe Inverter .....	15-16
Deluxe Inverter Optional Equipment Installation and Wiring .....	17-18
Torque Conversions .....	19
Controller Installation .....	21-24
Alternate Set-Up Options .....	25-27
Set Up and Operation .....	29-32
Fuji Inverter Functions & Features .....	33-34
Programming Parameter Settings on All Inverters .....	35
Parameter Settings for Fuji MEGA Drives .....	36-38
Reflex System Maintenance .....	39
Troubleshooting .....	41-44
Reflex Wiring Configurations .....	45-46
Technical Support Contact Information .....	47



# IMPORTANT

Thank you for your purchase of our **REFLEX** System.

We strongly recommend that you read the Frenic Mega Instruction Manual's Preface that refers to safety and warnings **BEFORE** you begin installation.

This **REFLEX** Manual is a **GUIDE ONLY** and covers most of the main parts of a normal installation and setup of our **REFLEX** System. It is important, however, to refer to the Frenic Mega Instruction Manual for more details on installation instructions and information.

Thank you.

## **BEFORE YOU BEGIN...** *Determining Placement*

Before determining placement of your Inverter System, please note it's critical **NOT** to install Inverter on a flammable surface OR in a location where water or moisture may be present. Internal damage or failure to Inverter which results from not following such precautions is **NOT COVERED UNDER WARRANTY.**

**IT IS CRITICAL THAT INSTALLERS READ AND FOLLOW THE FUJI INSTALLATION GUIDELINES TO PREVENT VOIDING THE MANUFACTURER'S WARRANTY.**

The Manufacturer's Warranty **DOES NOT** cover negligence or misuse of Inverter which includes water, chemical, dust, dirt or any other foreign matter or environment-related material getting inside the Inverter.

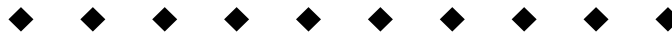

## **BEFORE YOU BEGIN...** *Check Existing Power*

Fuji wants to see a balanced 3 phase power with voltages very close to the same on all 3 phases. Measure these phases Leg to Leg to Leg.

If you **DO NOT** have a 3 Phase installation with this kind of power situation, we recommend you order the proper REFLEX System in the rated Horse Power for a Single Phase system.

Fuji Electric indicates it is better to wire up as a Single Phase and use the balance Legs on this system to the input of the Inverter.

**\*\*\* IMPORTANT \*\*\***

**Determine power needs BEFORE quoting as pricing will be different between Single and 3 Phase Reflex systems.**

# INTRODUCTION

The **REFLEX** unit was designed by NuPulse Inc. **REFLEX** senses the vacuum level in the milking system and controls the speed (RPM) of the electric motor driving the pump. The pump runs just fast enough to produce the needed air flow at the set vacuum level. As the need for air flow is introduced by the attachment and detachment of milker units, and activation of takeoffs, the Controller causes the vacuum pump to change speed accordingly. The result is a smooth, quiet vacuum pump operation which maintains a very stable level in the system and costs considerably less to operate. On farm experience has shown as much as 70% reduction in electrical usage by the vacuum pump. The payback for the system depends on the size of the pump and the number of hours per day of operation. Generally, an operation with a milking time of 10 hours per day will realize a payback within 2 years.

There are other benefits besides energy savings and quick payback. The system greatly reduces the noise of the vacuum pump and extends its life. With the built-in illuminated digital vacuum gauge you can easily see the vacuum stability and fast response time. The vacuum level is held steady and true.

Stand-Alone Inverter  
WITH NEMA 1 Kit



**REFLEX** Controller

Included with both Stand-Alone and Deluxe Units.

Deluxe Inverter in Cabinet





# ELECTRICAL SPECIFICATIONS

## Reflex VSD System's Electrical Installation Parts

### **IMPORTANT**

***All cable, wiring & relays must meet the current installation site's compliance standard for electrical wiring for that area. Check with a local certified electrician.***

### **All Systems**

See Pages 49-50 for illustrations of Cable Configurations.

**18/2 Shielded Control Cable**– For low voltage 4-20 ma connection of the **REFLEX** Controller to the Frenic Fuji Inverter. The Cable must be routed away from other electrical wiring.

**18/3 Cable or wire**- For the 120 volt AC signal from the main System's Milk/Wash Switch (Washer Panel). If only one vacuum pump signal is available or to be used an 18/2 Cable or wire can be used instead.

**Relays**– Must be used if the Milk/Wash Signal is not 120 volts AC. Also used if wanting to isolate the 120 volt AC signal power from the main System's Milk/Wash Switch. Two Relays are required if using separate Milk and separate Wash Signals. The Relay must be at least a SPST with contacts that are rated at 120 volts AC at 1 amp min. The Relay coil voltage must match that of the Milk/Wash power signal.

**Below are specifications of what is needed for the high voltage cable & wiring of the Inverter. We recommend using a VSD rated Cable on the Inverter Output.**

### **230 Volt Single Phase Systems**

#### **Power Cable or wire from Breaker Panel to Inverter input**

**5HP** - 8 AWG, 3 Conductors, 55A Cont

**7 HP**- 6 AWG, 3 Conductors, 70A Cont

**10 HP**- 4 AWG, 3 Conductors, 95A Cont

**15 HP**- 2 AWG, 3 Conductors, 130A Cont

#### **VSD Power Cable from Inverter output to Electric 3 Phase Motor**

**5, 7.5 & 10 HP**- VSD Cable 12 AWG, 4 Conductor, 30A Cont

**15 HP** - VSD Cable 8 AWG, 4 Conductor, 55A Cont



## 230 Volt Three Phase Systems

### **Power Cable or wire from Breaker Panel to Inverter input**

**5HP**- 14 AWG, 4 Conductors, 25A Cont

**7.5HP** - 12 AWG, 4 Conductors, 30A Cont

**10 HP**- 10 AWG, 4 Conductors, 40A Cont

**15 HP**- 8 AWG, 4 Conductors, 55A Cont

**20 HP**- 6 AWG, 4 Conductors, 70A Cont

**25 HP**- 4 AWG, 4 Conductors, 95A Cont

**30 HP**- 2 AWG, 4 Conductors, 130A Cont

### **VSD Power Cable from Inverter output to Electric 3 Phase Motor**

**5, 7.5 & 10 HP**- VSD Cable 12 AWG, 4 Conductor, 30A Cont

**15 & 20 HP** - VSD Cable 8 AWG, 4 Conductor, 55A Cont

**25 & 30 HP**- VSD Cable 4 AWG, 4 Conductor, 95A Cont

## 460 Volt Three Phase Systems

### **Power Cable or wire from Breaker Panel to Inverter input**

**5HP**- 14 AWG, 4 Conductors, 25A Cont

**7.5HP**- 14 AWG, 4 Conductors, 25A Cont

**10 HP**- 14 AWG, 4 Conductors, 25A Cont

**15 HP**- 12 AWG, 4 Conductors, 30A Cont

**20 HP**- 10 AWG, 4 Conductors, 40A Cont

**25 HP**- 8 AWG, 4 Conductors, 55A Cont

**30 HP**- 6 AWG, 4 Conductors, 70A Cont

### **VSD Power Cable from Inverter output to Electric 3 Phase Motor**

**5, 7.5, 10 & 15 HP**- VSD Cable 12 AWG, 4 Conductor, 30A Cont

**20, 25 & 30 HP** - VSD Cable 8 AWG, 4 Conductor, 55A Cont

# FUJI FRENIC INVERTER RATINGS

## Fuji Frenic Inverter Current Ratings

Power to the Inverter must have an independent Circuit Breaker and wire run from the electrical panel, not shared with other equipment.

Below are the **REFLEX** System's Maximum Input Current Ratings for each package. Have the Electrician select the proper Circuit Breaker for these current ratings.

**Note \* All circuit breakers, cable and wiring must meet the current installation site's compliance standard for electrical wiring for that area. Check with a local certified electrician.**

These ratings do not reflect the actual operating current or average power consumption of the system. They do reflect the peak currents that could occur during startup and what the Inverter is capable of handling for current draw. A Circuit Breaker selected too small for the system may have you having nuisance trips if underrated. The Inverter has an electric motor name plate current setting that will be selected after the installation is complete. This, once set, will protect the electric motor.

### 230 Volt Single Phase Systems Input Current

**5HP - 37 Amps**

**7.5 HP - 53 Amps**

**10 HP - 70 Amps**

**15 HP – 95 Amps**

### 230 Volt Three Phase Systems Input Current

**5 HP- 20 Amps**

**7.5 HP - 27 Amps**

**10 HP- 37 Amps**

**15 HP- 53 Amps**

**20 HP- 70 Amps**

**25 HP- 84 Amps**

**30 HP- 95 Amps**

### 460 Volt Three Phase Systems Input Current

**5 HP- 10 Amps**

**7.5 HP- 15 Amps**

**10 HP- 21 Amps**

**15 HP- 28 Amps**

**20 HP- 36 Amps**

**25 HP- 42 Amps**

**30 HP- 50 Amps**

# STAND-ALONE INVERTERS

## CHOOSING SYSTEM LOCATION FOR STAND-ALONE INVERTER

The Inverters are NOT in a wash down enclosure. They should be placed in a dry area as they are NOT water resistant. We recommend placing the system in the utility or pump room and next to the Vacuum Pump.

The drive should be installed in a conditioned cabinet or a ventilated enclosure. The Deluxe **REFLEX** System is a fan-cooled and ventilated NEMA 4 rated enclosure. Fuji Drives have NEMA 1 enclosures which are suitable for clean areas only. If something such as delicate paperwork cannot be left in the immediate vicinity of the drive, a NEMA 1 drive should not be placed there either. Check with the Fuji Drive Manual for other routine service requirements and environmental specifications.

### **WARNING**

***Install the inverter on a base made of metal or other non-flammable material.  
DO NOT place flammable object nearby AS FIRE COULD OCCUR.***

The Fuji Inverters are one of the most durable and reliable Inverters made. With that said, we have seen a small percentage of Inverters fail in the first 10 years. Of the failures in that time period, the overwhelming majority failed due to water or moisture damage in the first 2 years of installing them. About 40% of them were damaged during cleaning when a hose was used near there, or when another device sprung a leak on them. The other 60% failed from moisture dripping down on top of the unit from above. This moisture may be condensation or “sweat” from the ceiling or from other equipment mounted above the Drive. An equipment room may seem like a dry and safe location, however, condensation can still form on the ceiling or on equipment above, so there is always a possibility for droplets of water to form and drip.

Because of the conductivity of water, especially with high voltage, the shorting out of the circuitry in the Inverter is so damaging it renders it not worth repair. **NOTE: Water or moisture damage is NOT covered under Warranty.**

As a result of these findings, we have developed a Shroud to prevent this damage. Effective 6/20/11, a Plastic Shroud will automatically be included with all Stand-Alone or non-Deluxe **REFLEX** Systems to help eliminate the possibility of moisture from above damaging the unit and ultimately destroying the Inverter.

If you have existing Stand-Alone **REFLEX** Systems already in the field, you can order part #P19700NP Shroud to provide those customers with that little extra protection.

The photos below show proper placement of the Shroud above your Inverter.



***IMPORTANT***

If the Milk/Wash Room is your only option for placement, you must choose a Deluxe **REFLEX** Package for this installation. The chemical steam or mist can affect the air drawn into the **REFLEX** Drive, so we recommend you install a dry fresh air line to the intake vent on the Deluxe Cabinet, which is much like the duct work found on a clothes dryer.

With these points in mind, lay out placement of where the components of the system will be and determine what mounting hardware will be needed.

**MOUNTING THE COMPONENTS FOR STAND-ALONE INVERTER**

1. Find a clean dry area close to the vacuum pump to mount the Inverter. The Inverter system is very heavy and should be bolted into something secure. Follow the points listed below. Violating the conditions listed may void the warranty of the Inverter.
  - a. Do not install the Inverter in a place subject to high temperature (over 100 F), high humidity, or excessive vibration.
  - b. Mount Inverter system vertically; do not restrict the air flow to the heat sink fans.
  - c. The Inverter generates heat. Allow sufficient space around the system for air circulation. (More than 12 inches in all directions.)
  - d. Do not mount the Inverter system above heat-generating equipment or in direct sunlight.

- e. If mounting Stand-Alone Drive in an area that may have occasional dripping, precautions must be made to prevent moisture from falling on the Inverter as it is **NOT** in a water resistant enclosure. A protective Shroud is provided and should be installed per the instructions included.
2. Mount the **REFLEX** Enclosure in the parlor so it can be seen by the milkers, since there is a digital vacuum gauge that shows the system vacuum level. This enclosure is water resistant, but should not be sprayed directly. See Page 21 for mounting and hook-up instructions.

### WIRING THE MEGA DRIVE FOR STAND-ALONE INVERTER

1. First loosen the front cover fixing screw, slide the cover downward holding both sides, tilt it toward you, and then pull it upward, as shown below. While pressing the wiring guide upward, pull it out toward you. After carrying out wiring (see Sections 2.3.2 through 2.3.6), put the wiring guide and the front cover back into place in the reverse order of removal.



2. Wire the Inverter to a constant power source. Refer to Pages 7-10 for electrical wiring specifications, i.e. recommended cable size, circuit protection, tightening torque, etc.
3. For connecting to Single Phase Input Power, use input terminals “L1” and “L3”, leaving “L2” empty. When powered on, disable the Phase Drop Off Protection by changing parameter “H98” to a “00010001”. Failure to do this may result in phase loss faults.
4. It is not recommended to switch power on and off to the Inverter. If it is necessary to do so, the following should be done.
  - Install a wire jumper between “CM” and “FWD” on the control circuit terminal strip.
  - Change the “F02” program parameter from “0” to “1”.

**NOTE**

With a jumper wire connected between “CM” and “FWD” as noted above, parameters “F01”, “F02”, “F42”, “H08” and “H98” cannot be changed. If it is necessary to change these parameters, disconnect the jumper wire and reconnect after change is made.



***WARNING***

**Disconnect electrical supply before servicing the electrical system**

5. Drive output terminals (U, V, W)

Connect these terminals to a three phase motor in the correct phase sequence. If the direction of motor rotation is incorrect, exchange any two of the U, V, and W phases.

**Example:** Match the T1, T2, T3 on the Motor Plate to the corresponding U, V, W on the inverter.

These terminals need to be tightened to a certain torque. See Page 19.

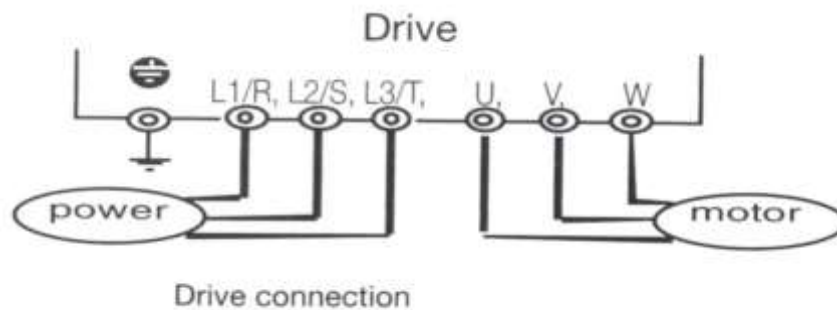

# DELUXE INVERTERS

## MOUNTING THE COMPONENTS FOR DELUXE INVERTER IN CABINET

1. Find a clean dry area close to the vacuum pump to mount the Deluxe Inverter systems. The cabinet is very heavy and should be bolted into something secure. Follow the points listed below. Violating the conditions listed may void the warranty of the **REFLEX** Inverter system.
  - a. Do not install the Inverter in a place subject to high temperature (over 100 F), high humidity, or excessive vibration.
  - b. Mount Deluxe cabinet vertically with the air filtered intake on lower left side and the exhaust outlet on upper right.
  - c. The Deluxe Inverter Unit generates heat. Allow sufficient space around the system for air circulation. (Allow more than 4 inches in all directions.)
  - d. Do not mount the Deluxe Inverter cabinet above heat-generating equipment or in direct sunlight.
  - e. If mounting Deluxe Inverter cabinet in an area that may have high moisture or condensation, we recommend ducting the intake air to a dry, clean air source using flexible tubing such as that used on dryer systems.
2. Mount the **REFLEX** Enclosure in the parlor so it can be seen by the milkers, since there is a digital vacuum gauge that shows the system vacuum level. This enclosure is water resistant, but should not be sprayed directly. See Page 21 for mounting and hook-up instructions.

## WIRING THE MEGA DRIVE FOR DELUXE INVERTER IN CABINET

1. First loosen the front cover fixing screw, slide the cover downward holding both sides, tilt it toward you, and then pull it upward, as shown below. While pressing the wiring guide upward, pull it out toward you. After carrying out wiring (see Sections 2.3.2 through 2.3.6), put the wiring guide and the front cover back into place in the reverse order of removal.

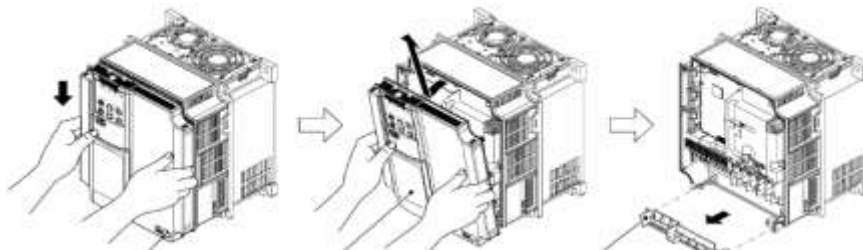

2. Wire the Disconnect Switch to a constant power source. Wire the Inverter to a constant power source. Refer to Pages 7-10 for electrical wiring specifications, i.e. recommended cable size, circuit protection, tightening torque, etc.



3. For connecting to Single Phase Input Power, use input terminals “L1” and “L3”, leaving “L2” empty. When powered on, disable the Phase Drop Off Protection by changing parameter “H98” to a “00010001”. Failure to do this may result in phase loss faults.
4. It is not recommended to switch power on and off to the Inverter. If it is necessary to do so, the following should be done.
  - Install a wire jumper between “CM” and “FWD” on the control circuit terminal strip.
  - Change the “F02” program parameter from “0” to “1”.

**NOTE**

With a jumper wire connected between “CM” and “FWD” as noted above, parameters “F01”, “F02”, “F42”, “H08” and “H98” cannot be changed. If it is necessary to change these parameters, disconnect the jumper wire and reconnect after change is made.



***WARNING***  
**Disconnect electrical supply before servicing the electrical system**

5. Drive output terminals (U, V, W)

Connect these terminals to a three phase motor in the correct phase sequence. If the direction of motor rotation is incorrect, exchange any two of the U, V, and W phases. These terminals need to be tightened to a certain torque. See Page 19.

**Example:** Match the T1, T2, T3 on the Motor Plate to the corresponding U, V, W on the inverter.

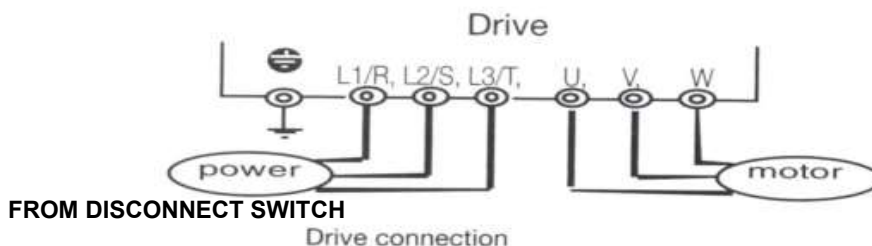

# DELUXE OPTIONAL EQUIPMENT

## INSTALLING OPTIONAL EQUIPMENT IN DELUXE CABINET



Install the Line Reactor and RFI Filter in the locations shown above by following the instructions below. Mark the mounting holes first, then drill and tap threads to bolt the items to the back plate making sure not to let metal filings drop into the Fuji Inverter.

Disconnect the wires from the Disconnect Switch going to the Inverter.

From the Disconnect Switch, run a new set of wires to the input of the Line Reactor.

Then from the output of the Line Reactor, run wires from it to the Input of the RFI Filter.

Take the wires which you unhooked from the Disconnect Switch on the Inverter and wire them to the output of the RFI Filter.

Power wires should interconnect as illustrated in the diagram below.



## **OPTIONAL EQUIPMENT WIRING FOR DELUXE INVERTER IN CABINET**

### **Wiring the Line Reactor**

1. "U1", "V1" and "W1" terminals are the Inputs from the Power on the Line Reactor.
2. On a Deluxe Cabinet, wire the Disconnect Switch Output "L1" to "U1", "L2" to "V2" and "L3" to "W1".
3. "U2", "V2" and "W2" terminals are the Outputs to the Inverter on the Line Reactor.
4. On single phase power, hook wiring to only the "U" and "W" terminals.
5. Leave the "V" terminals empty.
6. The Cabinet Back Plate is grounded when the Ground is connected on the Din Rail Terminal at the Disconnect Switch. When mounting the Line Reactor, scrape off a little paint to ensure a good Ground to it.

### **Wiring the RFI Filter**

1. On the LINE side of the RFI Filter, "L1", "L2" and "L3" are the Inputs from the Power.
2. If you have a Line Reactor, wire "U2" to "L1", "V2" to "L2" and "W2" to "L3".
3. On the Load side of the RFI Filter, "L1", "L2" and "L3" are the Outputs to the Inverter.
4. Connect "L1" to "L1", "L2" to "L2" and "L3" to "L3" to connect the RFI Filter to the Inverter.
5. On 1 Phase Power, hook wiring to only the "L1" and "L3" terminals.
6. Leave the "L2" terminals empty.

#### **NOTE**

See Page 19 for instructions to tighten torque of Inverter terminals above.

# TORQUE CONVERSIONS

## FUJI FRENIC POWER INPUT/OUTPUT TERMINAL TORQUE RECOMMENDATIONS

The wire terminals “L1”, “L2”, “L3” and “U”, “V”, “W” on the Inverter must be tightened with a Torque Wrench to the specifications listed below. If these connections are not tight enough, the heat generated from a loose connection will cause these terminals to overheat and melt both the terminal and wire connection.

The Torque listed below is in Newton Meters (N·m)

- 5HP Inverters: Torque to 1.8 N·m
- 7.5, 10 and 15HP Inverters: Torque to 3.5 N·m
- 20, 25 and 30HP Inverters: Torque to 5.8 N·m

Torque Conversions
$N \cdot m = \text{in. lb.} \times 0.113$
$N \cdot m = \text{ft. lb.} \times 1.356$
$\text{In. lb.} = N \cdot m \times 8.85$
$\text{Ft. lb.} = N \cdot m \times 0.737$



# CONTROLLER INSTALLATION

## CHOOSING REFLEX CONTROLLER LOCATION

The **REFLEX** Controller is designed to be mounted in the parlor so that the vacuum gauge can be seen while milking. It is in a Nema 4 enclosure that is water resistant, however, it should NOT be sprayed directly with a pressure hose. The tap for sensing the vacuum should be placed 24" to 48" from the sanitary trap on the vacuum pump side. The **REFLEX** Controller should be mounted higher than the tap hole and no further away than 36" away from the tap hole. This will allow moisture in the sensing tube to drain back into the vacuum line.

In order to ensure no damage occurs to the **REFLEX** Circuit Board during shipping, it is packaged separately. It has to be mounted inside the enclosure upon installation of the system. Standoffs are already mounted in the back portion of the box to which the circuit board attaches.

## MOUNTING THE REFLEX CONTROLLER

1. Remove the **REFLEX** cover from the box.
2. Remove the package of hardware from the box. Hardware includes:
  - 4 x Mounting Screws
  - 4 x Nylon Washers
  - 2 x Tie Straps
  - 1 x 3 Connector Plug
  - 1 x 2 Connector Plug
  - 4 x #6 x 3/8" Screws
  - 4 x #6 Nylon Washers
  - 1 x Brass Barb
3. Remove the circuit board from bubble-wrap.
4. Connect the vacuum tubing which is connected to the brass adapter inside box onto the black sensor on the top backside of the circuit board. Secure it in place using a black 4" tie trap provided.
5. Fasten the circuit board to the standoffs in the back of the box using the 4 screws and nylon washers provided.

### **NOTE**

The nylon washers should be installed between the bolt heads and the circuit board.

6. This completes the circuit board mounting. There is no need to reinstall the **REFLEX** cover at this time as it needs to be removed later for wiring.
7. Drill a 3/8" hole in the vacuum pipe that comes from the vacuum pump to the sanitary trap. The hole should be located 24" to 48" from the sanitary trap on the vacuum pump side. Since there is 36" of tubing provided, it should be no more than 36" from the **REFLEX** Controller.
8. Thread the brass tap into the hole that you just drilled. Connect the tubing from the **REFLEX** Controller onto the tap.

### **PARTS NEEDED**

#### **(ADDITIONAL ELECTRICAL & WIRING REQUIREMENTS - SEE PAGES 7-10)**

1. Mounting hardware for the Inverter and **REFLEX** Controller
2. Vacuum Relief Valve
3. Electric Conduit
4. Circuit Breaker
5. Cable and Wire

### **WIRING YOUR REFLEX CONTROLLER**

The **REFLEX** needs a 120 volt power from the Master Control/Washer. The power is separated for wash and milking. This will tell the Controller when to run at the wash cycle vacuum level and the milking vacuum level.

Wiring between the washer switch and **REFLEX** Controller should be such that 120 volts A.C. is sent to the Controller "**Milk**" terminal when the switch is in milk position and 0 volts to the "**Wash**" terminal. With the washer switch in Wash position, 120 volts A.C. should be sent to the Controller "**Wash**" terminal and 0 volts to the "**Milk**" terminal.

#### **NOTE**

To assist with wiring, please refer to Pages 45-46 for wiring configurations.

1. If you are using a Wash Signal , run a 3 conductor, 18 gauge wire from the Washer Control or a Master Control panel to the **REFLEX** Controller. This wire will provide a 120 VAC signal to the **REFLEX** Controller to tell it whether the milking system is in a “Wash” or “Milk” Mode. The **REFLEX** will then control the vacuum to the preset level for the mode being used. Run the wire up through the water tight connector and connect to the terminal block labeled “Power Input”. Connect the white wire to the “N” terminal, the Black wire to the “Milk” terminal and the remaining conductor to the terminal marked “Wash”.
2. If there is only one vacuum pump signal available from the Washer/Master Controller, then an 18/2 wire is all you will need. Connect only the Milk and “N” terminals.

**NOTE**

3 Conductors are needed ONLY if you want a separate vacuum level for WASH.

3. An 18/2 gauge shielded cable must be run from the Inverter to the **REFLEX** Controller. At the **REFLEX**, run the cable up through the water tight connector in the bottom left of the enclosure and connect to the 2-pole terminal labeled “1 & 2”. Connect the wire from “C1” at the inverter to “+/1” at the **REFLEX** and from “11” at the inverter to “-/2” at the **REFLEX**.



If the shield wire is needed, the shield drain wire can be grounded to an earth ground at **BOTH** ends to dissipate the RF emissions. At the inverter, earth ground should be the green ground terminal. At the **REFLEX** Controller, a single conductor wire should be connected to the shield drain wire and routed to an earth ground. Ideally this would be a ground rod but aside from new installations, this may not be possible. In existing installations, metal water piping or stall works may work as an earth ground. If connecting to water piping, use a commercially available ground clamp. If connected to stall works, it is preferred to drill and tap a hole for a ground lug (available at electrical supply outlets) to ensure a long-term positive connection versus using a hose clamp or strap.

**IMPORTANT**

The shield drain wire in the 18/2 cable should only be used if, after a system check, interference is found on the 4 to 20ma signal. In most installations, the shield wire does not need to be connected to an earth ground.

**WE STRONGLY SUGGEST YOU DO NOT HOOK THESE UP UNLESS NEEDED.**



**TOOLS NEEDED BEYOND THE BASICS**

When installing a **REFLEX** Variable Drive System there is a digital vacuum gauge that is displayed on the front of the **REFLEX** Controller. This gauge should be calibrated so that the system vacuum is accurate. In order to do this properly, it should be compared to a mercury gauge or equivalent.

# ALTERNATE SET-UP OPTIONS

## **REFLEX AND THE WASH CYCLE**

The **REFLEX** has a separate vacuum control level adjustment for the Wash Cycle.

Some installations prefer not to run Variable Speed during Wash and prefer to run off a Vacuum Regulator.

To get the Vacuum Regulator to kick in during Wash, adjust the **REFLEX** Wash vacuum level setting higher than that of the Vacuum Regulator.

This will make the Vacuum Pump System run wide open and be controlled by the Vacuum Regulator.

## **REFLEX CONTROLLER BYPASS (OPTIONAL)**

**To pre rig the system to run the vacuum pump system automatically without the REFLEX Controller, do the following:**

1. You need a 120 volt Relay with a normally open set of contacts SPST (Our part# P05010NP).
2. Supply the Relay COIL with the same 120v power you are sending to the **REFLEX** Controller. If you have a separate signal for Milk and Wash, you will need two (2) Relays.

### **IMPORTANT**

**Relay is a DRY contact which means NO POWER TO CONTACTS.  
120v power is ONLY FOR ACTIVATING COIL.**

3. Connect the normally open contacts of the Relay to the Inverter's input terminals "CM" and "FWD".
4. Change the "F02" parameter of the Inverter from a "0" to a "1".

You are now done with the configuration for the bypass if needed.

**To run in Bypass Mode of the REFLEX Controller you must do the following:**

(This would allow you to run off the inverter if there was a problem with the **REFLEX** Controller.)

1. You must program parameter "F01" from a "2" to a "0".
2. Exit the program mode, and press the "up arrow" key to select the HZ you want the system to run at (if system capacity is at max for wash, select 60 HZ).
3. Start it up and set your Vacuum Controller to the proper milking vacuum level.

(Note: The normal setting for the installation was set at 1"hg higher than the wash vacuum level of the **REFLEX** System.)

**CONNECTING 1 REFLEX CONTROLLER TO 2 INVERTERS**

**The REFLEX Controller's 4-20 milliamp output (terminals 1 & 2) can be connected in series to two different Inverters.**

- The wire coming from the **REFLEX** Control terminal number 1 (positive) connects to first Inverter's (Inverter #1) control circuit terminal "C1".
- The wire coming from the **REFLEX** Control terminal number 2 (negative) connects to second Inverter's (Inverter #2) control circuit terminal "11".
- In order to finish the **REFLEX** connections to run the two Inverters in series, you must run a wire from the Inverter #1's number "11" terminal to the Inverter #2's "C1" terminal.

**CONNECTING 1 REFLEX INVERTER TO 2 ELECTRIC MOTORS**

**Before calling us, please have the following information below.**

We must know what the Full Load Amps (FLA) ratings are on each of the electric motors.

Because the inrush current of the two motors to the Inverter can be high, we must determine the proper HP rating for your Inverter. If it's for a Single Phase power system, the HP will need to be double the FLA rating.

The FLA rating can be found on the electric motor's name plate.

We also suggest a power distribution box be used to terminate the two motor power cables to one Inverter. A poor connection to the Inverter's Terminal Block can result in destroying it due to high resistance which could melt the Terminal Block.

### **INVERTER SOFT START**

On some systems, it takes too long for the vacuum to appear on the Reflex Sensor which defeats the Reflex Soft Start, even at its longest 90-second setting.

The steps below explain how to set up a Soft Start on the Inverter if needed. These settings also should be set for systems where the power is turned On/Off to the Inverter with the Main Milk/Wash Switch.

1. Starting frequency 1 Parameter F23 Data setting range: 0.0 to 60.0 (Hz).
2. F23 specifies the starting frequency at the startup of an Inverter. Under V/f control, even if the starting frequency is set at 0.0 Hz, the Inverter starts at 0.1 Hz.
3. Starting frequency 1 (Holding time) Parameter F24 Data setting range: 0.00 to 10.00 (s) F24 specifies the holding time for the starting frequency 1.

We suggest setting Parameter F23 to “20 HZ” and Parameter F24 to “10 seconds” to start with. These can be set to your desired settings when done.



# SET-UP AND OPERATION

Before running the system, note the following considerations:

1. On our **REFLEX** Inverters, the operating parameters have been set at the factory. However, certain parameters will need to be programmed based on the installation requirements. Instructions on how to program operating parameters covered below in Steps 2-4 can be found under Parameter Settings for the Fuji P11 Drives on Pages 35-37 in this manual.
2. Enter the motor amp rating from the motor name plate into parameter "F11".
3. With single phase input power, change parameter "H98" to a "00010001". **FAILURE TO DO THIS MAY RESULT IN PHASE LOSS ALARM FAULTS.**

## **NOTE**

For complete instructions on how to operate the inverter keypad to make changes in parameters as noted above, refer to Page 35 in this Manual.

With all the wiring complete, the system will automatically turn "ON" with the automatic pipeline washer switch or power switch. Leave the existing vacuum controller in the system for a safety feature but set it at a higher vacuum level, or install a relief valve.

## **NOTE**

Prior to powering on the **REFLEX** Controller, the Inverter mode has to be changed from **STOP** Mode to **RUN** Mode.

## **NOTE**

The "FWD" key must be activated to show "Run" also. After a power outage or an Alarm Code reset, the Inverter must be reset to "Run" by depressing the FWD key.

When power is applied to the Inverter for the first time or any subsequent times, you will have to change the Inverter from the **STOP** Mode to the **RUN** Mode. This will also apply after resetting any alarm faults on the Inverter. Pressing the ‘FWD’ key on the panel will change the LCD display from **STOP** to **RUN** and illuminate a green light labeled RUN.

Turn power on to the **REFLEX** Controller in the “MILK” position.

The “SOFT START” timing control will cause the vacuum pump to start slow and gradually increase speed until the system vacuum level is reached or until the time has elapsed.

The “SOFT START” factory setting is 15 seconds. This setting can be changed as follows:

### SETTING THE “SOFT START” TIMING

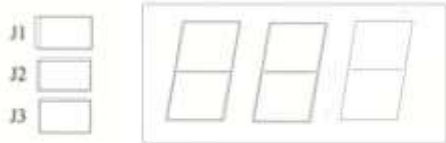

MINUTES Rev. D Boards	SECONDS Rev. D1/E Boards	J1	J2	J3
1	15	X	X	X
2	30		X	X
3	45			X
4	60	X	X	
5	75	X		
6	90			

X = Jumper On

1. There are 3 jumper connections located on the front side of the **REFLEX** circuit board, on the left side of the digital display. The position of these jumpers control the amount of time it takes for the pump to come to full speed potential, i.e. could go to 60 Hz if demand was there. The mode of operation for the “SOFT START” feature is that when power is turned on to the **REFLEX** Controller, the signal sent to the AC Inverter is such that it makes the motor start slowly and build speed gradually over the set time. After the time elapses, the operation is normal. The “SOFT START” timing sequence is reset each time power is turned off to the **REFLEX** Controller.
2. Select the “SOFT START” timing sequence which best fits the system configuration by placing jumpers as shown in the diagram on the left.

### CALIBRATING THE DIGITAL VACUUM GAUGE

1. Connect a mercury gauge or equivalent to the system to set the vacuum level and calibrate the vacuum gauge on the Controller.
2. Turn the switch to the Milking Position and the pump will start running.

3. With the **REFLEX** facing you, remove the cap on the left side. After the cap is removed, there is an adjustment screw on the circuit board. With a small screw driver, turn the screw clockwise to decrease the displayed number and counter clockwise to increase the number. See the Figure at right for clarification.

**IMPORTANT**  
 DO NOT ADJUST ANY OF THE SMALL  
 ADJUSTMENT SCREWS ON FRONT OF  
 BOARD. ONLY WORK WITH THE  
 ADJUSTING SCREWS THAT CAN BE  
 REACHED THROUGH THE SIDE OF  
 BOX BEHIND THE CAP.

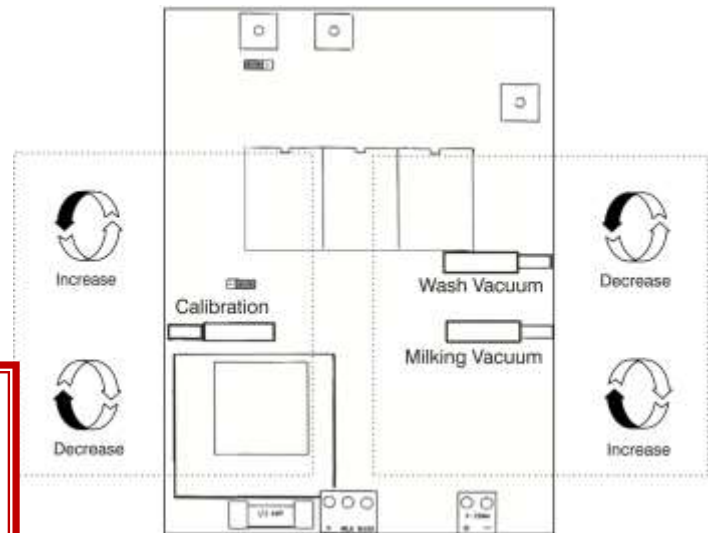

### SETTING THE MILKING VACUUM LEVEL

1. After the “SOFT START” timing sequence has elapsed, set the desired milking vacuum with the bottom adjusting screw on the right side of the Controller. See the above Figure for clarification. Factory setting is 12.5" Hg.
2. Replace the plug in the hole.

### SETTING THE WASH VACUUM LEVEL

#### **NOTE**

Needed ONLY if you want a separate vacuum level for WASH.

Turn power on to the **REFLEX** Controller in the “WASH” position.

1. After the “SOFT START” timing sequence has elapsed, and with milker units and air injector shut off, set the desired washing vacuum with the top adjusting screw on the right side of the Controller. See the above figure for clarification.
2. Factory setting is 14.0" Hg.
3. Replace the plug in the hole.





# FUJI FUNCTIONS & FEATURES

## The following are highlights from the Fuji Manual

With the inverter in the STOP Mode, you can scroll up or down in the Data Check Section and set all parameters and view all settings, and lock them out from accidentally being changed. Lockout can be done quickly and easily by programming Function "F00" to a "1". All functions showing an "\*" have been changed from factory settings and should match the function data chart in this REFLEX Manual.

Section 5 of the Fuji Manual also shows you how to access all the parameters that are useful for service and maintenance. You can check the input of the REFLEX Controller's "C1 Terminal" current, the motor's current draw and use the Hour Meter for maintenance of the vacuum pump. This section also shows you how to access the Alarm Code Faults in memory.

If the Inverter trips on an alarm, refer to "Protective Operations" in Section 6 of the Fuji Manual for a description of the Alarm Fault. Once you determine what the alarm is referring to, go to the Troubleshooting Section 6. This will have suggestions on how to troubleshoot and solve the problem that caused the alarm. To reset an alarm, press the 'Reset' key and the alarm will be reset and stored into the memory of the Inverter for future reference.

Maintenance and Inspection is covered in Section 7 of the Fuji Manual.



Display on keypad panel

## INVERTER PROGRAM MENU SCREEN

To enter and view the Inverter's Program Menu Screen, press the 'PRG' Key. This will illuminate the LCD and a list of nine different Functions. The Inverter will scroll instructions on the bottom of the LCD to show what keys to press to Enter, Exit and View the Functions.

The Functions are as follows:

### 0. QUICK SET

1. **DATA SET** - Mainly used for engineering purposes and a quick way to view the parameter's functions without referring to a manual. Entering the parameter number by pressing the 'FUNC/DATA' Key will display the parameter's settings.
2. **DATA CHECK** - A quick way to view what's been programmed in the Inverter's parameters and make changes to them. Parameter numbers followed by an "\*" have been changed from the factory settings. The numbers on the right show what the parameter is set at. Pressing the 'FUNC/DATA' Key will display the parameter's setting along with a description of its function.

3. **OPR MNTR** - This is a good place to view and monitor the Output Frequency, Output Current and the Output Voltage to the electric motor all at once. Pressing the 'FUNC/DATA' Key will display this feature.
4. **I/O CHECK** - You can view and monitor the 4 to 20 milliamp input from the **REFLEX** Controller and its DC voltage to the Inverter.

Pressing the 'FUNC/DATA' Key will enter the I/O Check screen area. Press the 'V' Key 3 times to advance to the 4<sup>th</sup> screen and "V2=" value will display the voltage reading from the **REFLEX** Controller. Pressing the 'V' Key again will advance to the 5<sup>th</sup> screen to display the "C1=" value to display what current is coming from the **REFLEX** Controller.

5. **MAINTENANCE** - Shows how many cumulative hours the Inverter have been in service and how many total hours the **REFLEX** System's vacuum pump has been running.

Pressing the 'FUNC/DATA' Key will enter the first screen. The "Time=" shows the cumulative hours the Inverter has been in service. Press the 'V' Key twice to advance to the 3<sup>rd</sup> screen. The "TCAP=" will show the hours of actual run time of the **REFLEX** System's vacuum pump.

6. **ALM INF** - Displays 9 screens of alarm information to help you troubleshoot the system. You will be able to see the time, frequency, voltage, current and a description of the alarm occurrence.
7. **ALM CAUSE** - Shows the history and cause of all alarms.

For more information on the Alarm Causes, refer to Section 6 in the Fuji Inverter Manual.

8. **DATA COPY** - For storing and sending program data from the Keypad to the Inverter or vice versa. Refer to the Fuji Manual for its use.
9. **LOAD FCTR** - You can run a timed test for up to 3600 seconds to see what the maximum and average output current to the electric motor during Milking or Wash.

10. **USER SET**
11. **COM DEBUG**

**NOTE**

The Inverter display **MUST** be in the 'REM' (Remote) Mode to operate with the REFLEX Controller. Also the 'FWD' Key must be activated to show "RUN". After a power outage or an Alarm Code reset, the Inverter must be reset to "RUN" by pressing the 'FWD' Key.

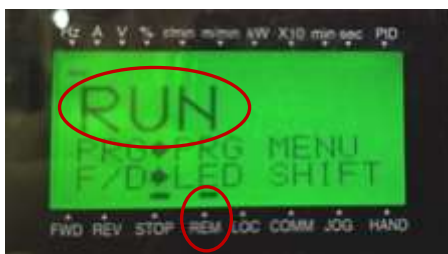

**CORRECT**



**NOT CORRECT**

# PROGRAMMING PARAMETERS

## NOTE

***The Inverter must be in the UNLOCKED Mode to be able to program parameter settings. Also some settings cannot be changed while the Inverter is in the RUN Mode. Press 'STOP' Key to enter the STOP Mode.***

## PROGRAMMING PARAMETER SETTINGS FOR ALL INVERTERS

1. Turn Power On to the unit.
2. Press 'PROGRAM' Key.
3. "QUICK SET" will appear on the LCD.
4. Scroll down using 'V' Key and highlight "DATA CHECK".
5. Press 'FUNC/DATA' Key on keypad.
6. Parameter setting will appear.
7. Use the 'Λ' or 'V' Keys to select parameters which are listed on Pages 36-37 of this Manual under "Parameter Settings for the FUJI P11 Drives".
8. When the parameter is selected to be changed, press the 'FUNC/DATA' Key.
9. Use the 'Λ' or 'V' Keys to select the change desired. If a large number appears, press 'SHIFT' Key to highlight the column you want to change.
10. Press 'FUNC/DATA' Key to store setting.
11. Follow the same procedure to make changes in any parameters.
12. To exit out of the PROGRAMMING Mode, press the 'RESET' Key twice.
13. Press 'FWD' Key to return to RUN Mode.

## QUICK WAY TO SCROLL IN THE DATA SET AND DATA CHECK PROGRAMMING

Depressing the 'SHIFT' Key and the 'Λ' or the 'V' Key at the same time will advance you to the next group of parameters without having to scroll through them all.

**PRE-PROGRAMMED PARAMETER SETTINGS FOR FUJI MEGA DRIVES**

Parameter settings in the DATA CHECK area show an “\*” after they have been changed from the factory settings. There are OVER 700 parameter settings in the Inverter, we are only using 20 of them.

Parameter Settings for the Fuji MEGA Drives The following are preset on Units when shipped from NuPulse			
	Parameter #	NuPulse Settings	Parameter Function
1	F01*	2	4-20mA Current Input
2	F07*	1.00s	Acceleration Time
3	F08*	.75s	Deceleration Time
4	F10*	2	Forced Air Motor O/L
5	F14*	3	Ride Through Momentary Power Drops
6	F26*	8 KHz	Motor Frequency (Noise)
7	F40*	150%	Torque Limit
8	F41*	0%	Prevents OU2 trip of Braking Torque
9	F42*	1	Torque Vector Active
10	H04*	5	Auto Reset for OU Alarms
11	H06*	1	Auto Fan Enabled
12	H08*	1	Reverse Lock Active
13	H11*	1	Coast to Stop
14	H96*	0	Disable ER-6 Fault Alarms
15	H98*	01010001	Detect Braking Disable  <b>NOTE: H98 is a binary number setting that is used for multiple functions. Using the 'SHIFT' Key is required to make a change to this Parameter.</b>

### **PARAMETER PROGRAMMING REQUIRED IN THE FIELD**

The following parameters need to be set on all inverters on site. Refer to Page 33 of this manual for setting instructions.

	Parameter #	Settings	Parameter Function
16	F11*	See setting instructions on Page 33 of this Manual	Motor Name Plate Current <b>Must be set to protect the motor and inverter.</b>
17	F00*	1— Lockout 0—Unlocked	Data protection <b>Use if you <u>DO NOT</u> want anyone to make a change.</b>
18	H98*	00010001	Phase Drop off Protection Disable <b>This setting must be entered for single phase inputs.</b>
19	C33*	.05 to .15	Set ONLY if needed to smooth out the pulsation response.

The following is only to be used if you want to clear the settings and start over with factory settings. All of the above parameters would have to be reprogrammed if used. You can use the Data Copy function to restore the data from the keypad memory. These settings are the same as programmed by NuPulse unless changed in the field.

	Parameter #	Reset Settings	Parameter Function
20	H03	1	Press 'STOP' and 'N' Key simultaneously, then press 'FUNC/DATA' Key which will reset all parameters to factory default settings.

### **CHANGING THE MAIN DISPLAY MONITOR**

The main display is factory set to show the output frequency. There are 12 other functions which can be selected to display, i.e. RPM of the motor, output voltage to the motor, output current to the motor and input power consumption display in kilowatts. To change the displayed function, enter into parameter E43 and change the program to correspond with the function of your choice. You can step through and view the functions by pressing the 'FUNC/DATA' Key.

**E-Zee Milking Equipment LLC has no responsibility for any Inverter NOT purchased from E-Zee Milking Equipment LLC *even though it may be connected to the NuPulse REFLEX Controller.* Please read your Inverter Manual for directions on set-up, features, maintenance and troubleshooting.**

# REFLEX SYSTEM MAINTENANCE

Although modern Variable Frequency Drives (VFD) have very few moving parts and very limited serviceability, there are several maintenance items which do require attention.

It is very important to check that the power terminals on the Drive stay tight. Loose power terminals can quickly heat up and fail, damaging the terminals and possibly the entire Drive. Loose terminals can also create a fire hazard.

Following the instructions per the Fuji Installation Manual, torque the terminals and regularly re-check that they have not loosened. After startup, and after several hours of operation, check that the terminals are still tight. It is necessary to check the terminals regularly afterwards. If the terminals stay tight, then longer intervals may be used between checks.

If you find terminals loosen regularly, check for excessive vibration at the terminals. Vibration may come from the wall the Drive is mounted on or through the power leads. This is more common on the output side of the Drive where the power leads go directly to the motor.

Drives require clean airflow for cooling. Cooling is typically accomplished with a heat sink and a fan. This heat sink assembly must be kept free of dust and dirt. Accumulations of debris in the heat sink can cause localized hot spots in the Drive. This heat can contribute to premature component failure. If you find the heat fins require frequent cleaning, that is your indication the Drive is in an unsuitable environment.

On Deluxe **REFLEX** Systems, make sure to check and clean the Intake and Exhaust Filters in addition to checking terminal connections on the Disconnect Switch and the optional Line Reactor and RFI Filter equipment.

The Inverter has a built-in Hour Meter which will help you determine when maintenance is due on the Vacuum Pump for things such as changing the oil. View the Run Time in hours under parameter "H94". Once maintenance is complete, you can reset the Run Time by pressing the 'V' Key back to "0".





# TROUBLESHOOTING

## **NOTE**

The Inverter display **MUST** be in the 'REM' (Remote) Mode to operate with the REFLEX Controller. Also the 'FWD' Key must be activated to show "RUN". After a power outage or an Alarm Code reset, the Inverter must be reset to "RUN" by pressing the 'FWD' Key.

## **REFLEX TOO RESPONSIVE TO THE PULSATION SYSTEM**

Some Pulsation systems turn all the Pulsators on at the same time and leak large volumes of air quickly and then close off the air admissions just as fast. Because the **REFLEX** is so responsive in maintaining the proper vacuum level, it can be a little jerky in it's response to following the large air admissions on those type of Pulsation Systems. If this is the case, adjust the Parameter listed below.

Parameter C33—REF Filter—Factory set at .05 set to .15

This will dampen the response to the pulsation thus smoothing out the jerkiness and sound on the Vacuum Pump. Settings of Parameter C33 higher than ".15" can make it seem even better, but if set too high the **REFLEX** may start to hunt and not lock in the vacuum level as quickly if there is a large air admission that is quickly closed off. (Example: Two milker units leaking in air from a fall off, then shut off or are reattached.)

**\*NOTE: Keep in mind the REFLEX must follow the response to the air leaked into the system to properly maintain Milking Vacuum level.**

## **PUMP WILL NOT RUN AND INVERTER SEEMS OKAY, BUT WILL NOT TRIP ON AN ALARM CODE**

If the Pump spins freely by hand, the Electric Motor may be bad and shorted out.

The Fuji Inverters have an instantaneous Over Current Detection feature set on the Inverter and shuts down the Output Voltage to the Electric Motor without tripping an Alarm Code in some Electric Motor problems.

You can temporarily disable that protection feature by changing Parameter H12 from a "1" to a "0".

Now run the **REFLEX** System and see what Alarm Code trips. Refer to Section 6 in the Fuji Manual for information on the Alarm Code and apply the recommended solution to your problem.

If you disconnect the Electric Motor leads from the Inverter and turn the **REFLEX** System on, you should be able to measure the high voltage on the Inverter's Output. This indicates the Inverter is fine and the problem lies within the Electric Motor.

The Fuji Keypad can be removed from the cover and plugged directly onto the Inverter socket for the Keypad. This will make measuring Output Voltages easier to complete.

### CHECKING THE ALARM CODES

In most cases, an 'unhappy' **REFLEX** Inverter will trip on some kind of an Alarm Code to alert you of what the problem is. Refer to Section 6 in the Fuji Inverter Manual to look up the Alarm Code for the suggested problem needing to be resolved.

See Pages 33-34 in this Manual for information on how to look up previous Alarms and Alarm History of the Inverter.

### POWER AND WIRING CHECK

Check that there is the proper incoming voltages to the **REFLEX** Controller and the Inverter. Make sure all wiring is completed properly and that there are no loose or poor connections.

You can view the Signal from the **REFLEX** Controller on the Inverter, refer to Page 34 in this Manual under Item #4 "I/O Check".

### PROGRAMMING CHECK

A **REFLEX** System that is not operating properly should have the Parameters checked or reinstalled before determining that a component is at fault.

You can check the Parameters that have been set on the Inverter by choosing Item #2 in "Data Check" under the Main Menu after pressing the "PRG" Key on the Inverter.

Once highlighted, press the 'FUNC/DATA' Key to enter and view the Parameter PROGRAMMING. It will show the Parameter number and follow with the setting. Refer to Pages 36-37 in this Manual for the settings.

Scroll using the 'Λ' and 'V' Keys to view the Parameters changed from the factory-default settings. For example, if Parameter F01 is followed by an "\*" symbol, that is an indication it has been changed from the factory setting.

Next refer to the Programming Chart to see if the setting is correct and whether it is even on the list. If it is not on the list, refer to Section 5 in the Fuji Inverter Manual for the factory setting and change it back.

To change the Parameter once it is highlighted, press the 'FUNC/DATA' Key to enter and change it using the 'Λ' and 'V' Keys.

If there seems to be a lot of incorrectly set Parameters, you could reset the Inverter to Factory Default Setting and reprogram it from scratch to save time. Refer to Parameter "H03" on Page 37 in this Manual for instructions on how to reset to Factory Default Settings.

### **IF THE REFLEX CONTROLLER GOES DOWN**

Following the steps below allows you to temporarily run your Vacuum Pump manually with the 'FWD' and 'STOP' Keys until your Controller is repaired.

1. On the Inverter Keypad press the 'STOP' Key
2. Press the 'PROGRAM' Key
3. "DATA SET" will appear on the LCD.
4. Scroll down using 'V' Key and highlight "DATA CHECK"
5. Press 'FUNC/DATA' Key on keypad to enter
6. A parameter setting will appear.
7. Use the 'V' or 'Λ' Keys to select parameter number "F01"
8. When the parameter is highlighted, press the 'FUNC/DATA' Key to enter
9. Use the 'V' or 'Λ' Keys to select the change desired.
10. Change this "F01" parameter from a "2" to a "1"
11. Press 'FUNC/DATA' Key to store setting
12. To exit out of PROGRAMMING Mode, press the 'RESET' Key twice
13. Prepare to adjust your Vacuum Regulator to your Milking Vacuum
14. Use the 'Λ' Key now to ramp the Hz in the LED display from "0 Hz" to "60 Hz"
15. Now run the Vacuum Pump by pressing the 'FWD' Key
16. Set your Milking Vacuum on the Regulator
17. To stop the Vacuum Pump, press the 'STOP' Key

### **SUDDEN VACUUM CHANGE WHICH WILL NOT ADJUST**

If you find the **REFLEX** Controller is not displaying and running the proper vacuum level at times and is running higher than it should, and your attempts for turning the vacuum level adjustment pots do not seem to be working, follow the instructions below to help determine if this problem is being caused by interference.

Check to see if the 18/2 cable from the **REFLEX** Controller to Inverter has its shield drain wire connected to earth grounds. If connected, go ahead and disconnect the shield wire from the grounds at each end to see if your vacuum levels go back to normal and you are able to adjust them. Being able to do so indicates the system was picking up interference off the grounds and back feeding into the **REFLEX** Controller Circuit. To avoid this continued interference, leave the shield drain wire disconnected from any grounds and trim the excess back to prevent any shorting out.

### IF ALARM CODE 'ECF' APPEARS

On the Frenic MEGA Inverters, if the "ECF" Alarm Code appears, following the steps below allows you to reset and run again.

1. Make sure your output cable as well as motor are not **ground** or **short**.
2. Make sure Inverter Control PCB **Connector** is securely connected.
3. Press 'RESET' and try to reset the alarm. If not reset by the 'RESET' button, cycle power the drive.
4. If you cannot reset by cycle power, please try to set a **u13=2** from 0 by while holding the 'STOP' Key and press 'Λ' Key. Then press 'FUNC/DATA' Key.

In order for you to access **u13(lower case u)**, please follow the instruction below.

1. Press 'PRG' Key to display keypad menu.
2. Select '2' Data Check and press 'FUNC/DATA' Key.
3. At F00 selected, press 'FUNC/DATA' Key.
4. At F00 value displayed, press and hold 'V' Key, then press and hold 'Λ' Key for a few seconds.
5. You should see 'u00'. If not, repeat Step #4 again.
6. Go to "u13" and change to "2" by pressing and holding the 'STOP' Key, then change the value by pressing 'Λ' Key.

# CABLE CONFIGURATIONS

## REFLEX CABLE CONFIGURATIONS FOR STAND-ALONE UNIT



System's Main  
Milk/Wash  
Control

18/3 or 18/2 Cable or Wire

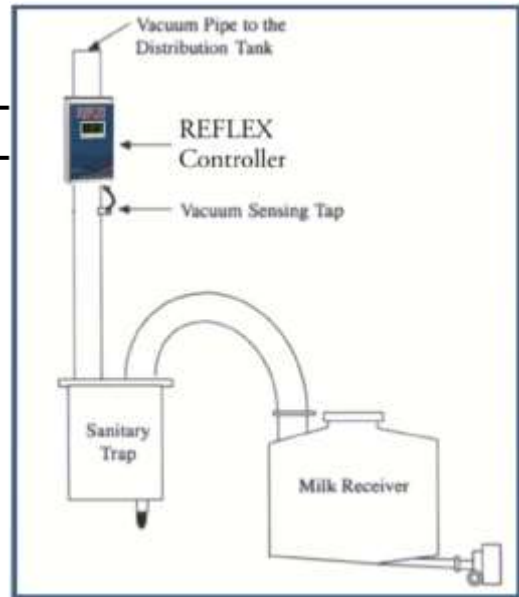

18/2 Shielded Cable

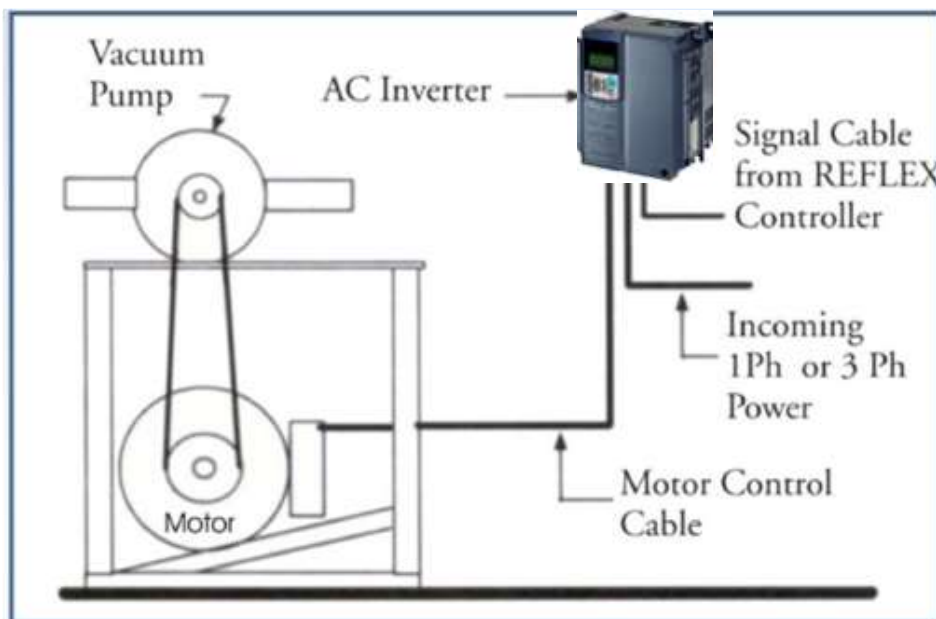

See  
Pages 7-8  
for sizing.

WIRING CONFIGURATIONS

**REFLEX CABLE CONFIGURATIONS FOR DELUXE UNIT**



System's Main  
Milk/Wash  
Control

18/3 or 18/2 Cable or Wire

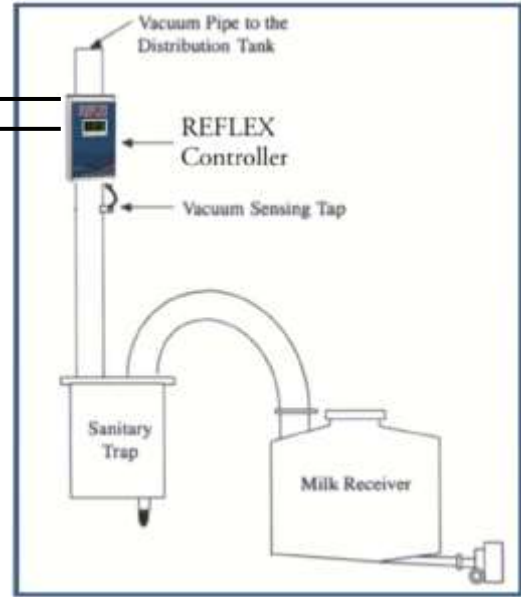

18/2 Shielded Cable

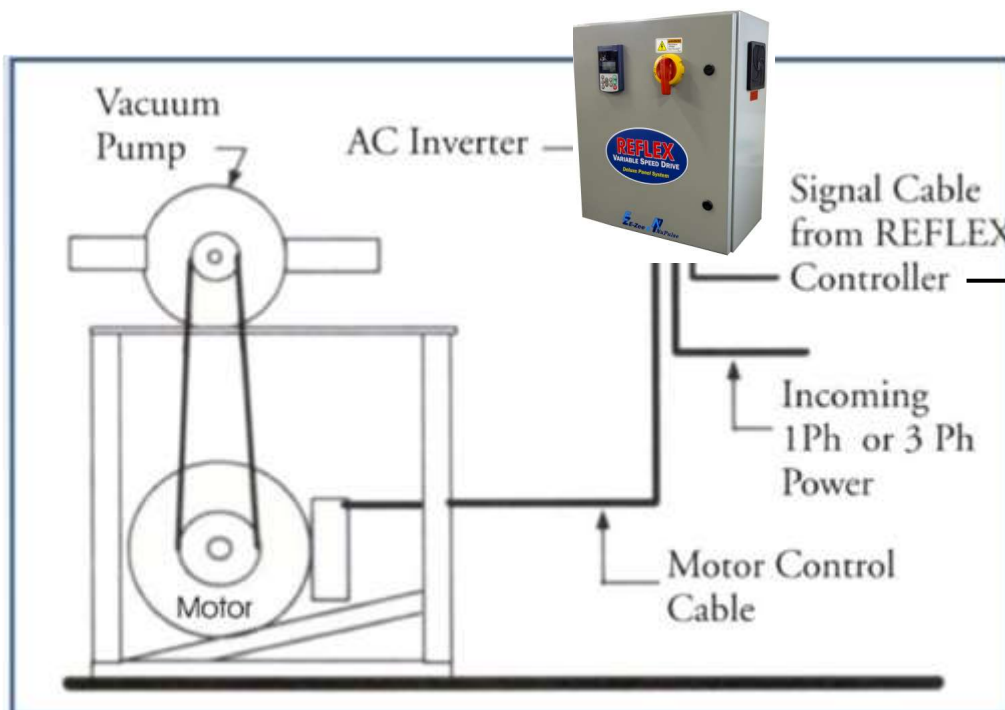

See  
Pages 7-8  
for sizing.

## TECHNICAL SUPPORT



**E-Zee NuPulse**  
**Tel: 800-729-4118**  
**Monday - Friday**  
**7:30 am - 4:30 pm (CST)**

**After Hours**  
**Gert Mogensen**  
**920-602-6724**

**Fuji Electric Corp of America**  
**Technical Support**  
**Tel: 847-397-8040**

**Fuji Answering Service (Inverter ONLY)**  
**Tel: 888-900-FUJI (3854)**

**Fuji Outside of USA**  
**Tel: 510-440-1060 Monday - Friday 8:00 am - 7:00 pm (CST)**  
**Tel: 510-870-3338 After Hours**



If you need additional REFLEX Manuals, please visit our website at [www.ezmilking.com](http://www.ezmilking.com) Click on “Manuals” on the left hand side and then on the “Reflex Manual” thumbnail. You can either print or download a copy to your computer.



# *NOTES*



E - ZEE NUPULSE

4904 Triangle Street, Suite A  
McFarland, WI 53558

Phone: 608-838-4448 / Toll Free: 800-729-4118

Fax: 608-838-2221

Email: [info@ezmilking.com](mailto:info@ezmilking.com)

Visit us on the web at  
[www.ezmilking.com](http://www.ezmilking.com)